



HA16 SPX HA18 SPX

Optimum verimlilik

- Tam oransal kumandalar ve eş zamanlı bom fonksiyonları
- Tam yüksekliğe 44 saniyede erişim

Arazide olağanüstü çalışma kabiliyeti

- 4 teker yürüyüş ile daha iyi manevra kabiliyeti
- Hidrolik diferansiyel kilit
- Yerden 38 cm'lik yükseklik

9.15 m'lik yatay erişim daha geniş bir çalışma eğrisi sağlar (HA16 SPX)



rentrise.com.tr
0850 460 5 460



HA16 SPX / HA18 SPX



DİZEL EKLEMLİ PLATFORM

Teknik özellikler

HA16 SPX HA18 SPX

Çalışma yüksekliği	16 m	17.3 m
Platform yüksekliği	14 m	15.3 m
Yatay erişim	9.15 m	10.6 m
Maksimum yatay erişimdeki yükseklik	6.5 m	6.5 m
Kaldırma kapasitesi	230 kg	230 kg
F x G Platform ölçüleri	1.8 x 0.8 m	1.8 x 0.8 m
A Uzunluk	6.8 m	7.5 m
Nakliye uzunluğu	5.15 m	5.8 m
B Genişlik	2.3 m	2.3 m
C Kapalı yükseklik	2.2 m	2.2 m
Nakliye yüksekliği	2.55 m	2.55 m
Dikey jib bom hareketi	140° (+70/-70)	140° (+70/-70)
Sepet dönüş (sağ/sol)	180° (+90/-90)	180° (+90/-90)
Kule dönüş	350°	350°
Kuyruk salınımı	0 m	0 m
D Aks merkezleri aralığı	2 m	2 m
E Yerden yükseklik	38 cm	38 cm
Eğim	5°	5°
Sürüş hızı	0.8 - 5.5 km/h	0.8 - 5.5 km/h
Tırmanma kabiliyeti	40 %	40 %
Dönme yarıçapı - dış	4.5 m	4.5 m
Lastikler - dolgu	14-17.5	14-17.5
Motor gücü	31.2 kW - 42.hp	31.2 kW - 42.4 hp
Hidrolik sistem kapasitesi	100 l	100 l
Yakıt tankı kapasitesi	72 l	72 l
Ağırlık	6700 kg	7660 kg

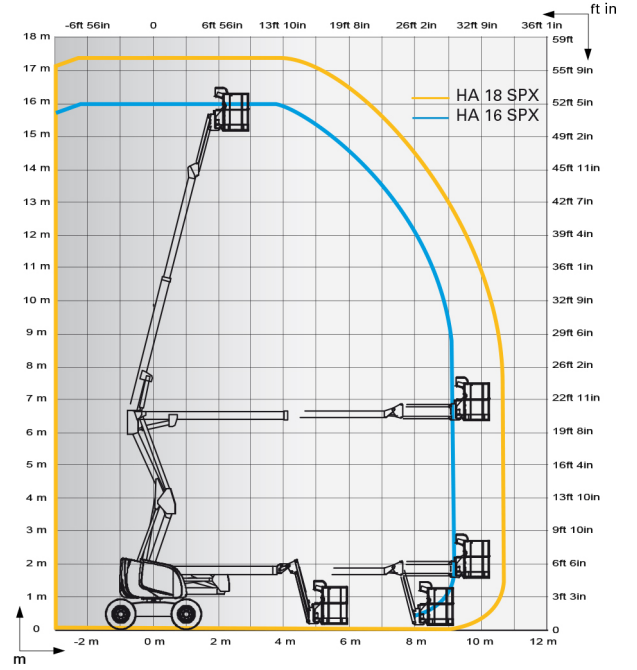

Standart özellikler

- 4 teker yürüyüş ve direksiyon
- Kesintisiz 350° kule dönüş
- 45km/h'lik rüzgar hızına kadar çalışabilme
- Kolay bakım: döner motor tablası
- 72 l yakıt tankı; 1.50 m doldurma yüksekliği
- 5° eğim alarmı
- 12 V akü / elektriksel kontrol sistemi
- Acil durumda indirme için sepette yardımcı güç kaynağı
- Fren serbest bırakma
- Çalışma saati
- Mekanik kule dönüş kilidi
- Çekme kancaları / kaldırma noktaları

Opsiyonlar ve aksesuarlar

- 3.3 kW dahili jeneratör
- Sepette güç kaynağı
- Geniş sepet 2.3 x 0.8 m
- Sürüş alarmı
- Döner lamba
- Çalışma ışığı
- Soğuk hava paketi
- Sıcak ortam kiti
- Sepette hava hattı

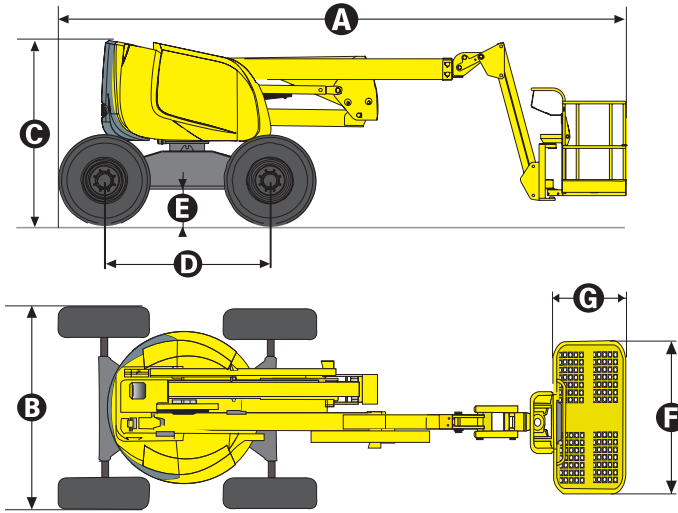

İstanbul Merkez :

Anadolu Mah. Kanuni Cad.
No: 30 Orhanlı 34956
Tuzla - İstanbul
Tel : 0216 970 50 70
Fax : 0216 970 50 80

İstanbul Avrupa :

İkitleli OSB Sefaköy San. Sit.
13. Blok No: 13-17 34500
Başakşehir - İstanbul
Tel : 0212 970 50 70
Fax : 0212 970 50 80

Ankara

OSTİM Mahallesi 100. Yıl Blv.
1229. Cad. No:1-3 06370
Yenimahalle - Ankara
Tel : 0312 970 50 70
Fax : 0312 970 50 80

İzmir :

Ankara Cad. Ulucak Beldesi
No: 17 35735
Kemalpaşa - İzmir
Tel : 0232 970 50 70
Fax : 0232 970 50 80

Bursa :

Demirci Mah. Ahıska Cad.
No: 191 16159
Nilüfer - Bursa
Tel : 0224 970 50 70
Fax : 0224 970 50 80

